

Perkomatic

R 85



Spring closing system with single adjustment

Application range

- . inside wooden single action doors with wooden door frame

Technical Data

- . door leaf concealed mechanism
- . mechanism with chain and spring
- . force 2
- . opening and self closing up to 180°
- . latching action adjustment
- . without hold-open

Finishings

- . polished brass
- . bright chrome

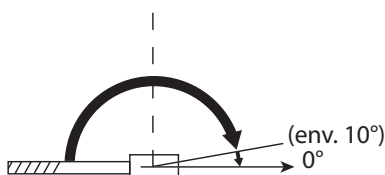

sevax

Closing solutions

Benefits

- . invisible
- . opening up to 180°
- . latching action

SAINT-GOBAIN
SEVA

Use conditions

- . maximum door weight : 75 kg
- . maximum door height : 2 400 mm

<i>Force</i>	<i>Maximum recommended door width</i>	<i>Maximum opening torque (0-4°)</i>
2	850 mm	10 Nm

Note : the above mentioned values are given for standard use conditions : without wind and without vandalism.

Assembly

Dimensions

- . mechanism : 194 x 125 x 25,4 mm
- . minimum door leaf thickness : 35 mm

An assembly instruction sheet is delivered in packaging.

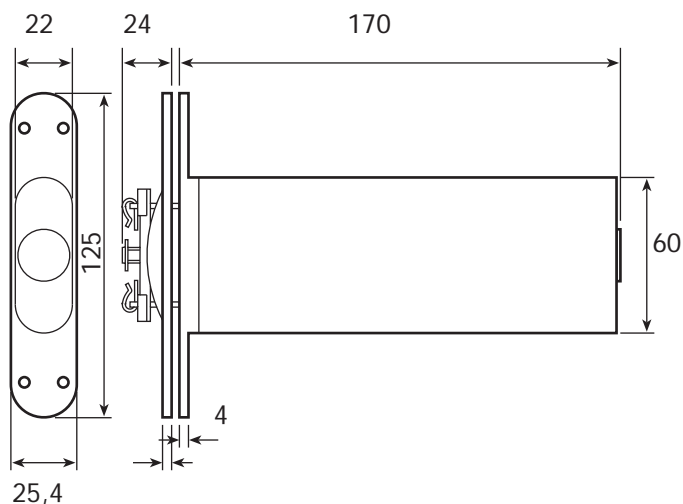

SAINT-GOBAIN
SEVA

SAINT-GOBAIN SEVA

43, rue du Pont de Fer - BP 10176
71105 CHALON-SUR-SAÔNE cedex
FRANCE

Tél. : +33 (0)3 85 47 25 59
Fax : +33 (0)3 85 47 25 38

www.sevax.com



Les renseignements figurant dans ce document sont donnés à titre indicatif et ne sont pas contractuels.

References

<i>Designation</i>	<i>bright chrome</i>	<i>polished brass</i>
PERKO - Perkomatic R85	FP00R85LC	FP00R85LP